

INSTALLATION AND MAINTENANCE INSTRUCTIONS

4PGE/SG(13,15) Series

Gas Heating/Electric Cooling Package Unit

Save these instructions for future reference

WARNING

Improper installation, adjustment, alteration, service, or maintenance can cause injury or property damage. Refer to this manual. For assistance or additional information, consult a qualified installer, service agency, or the gas supplier.

WARNING

Do not store combustible materials, including gasoline and other flammable vapors and liquids, near the furnace, vent pipe, or warm air ducts. Such actions could cause property damage, personal injury, or death.

WARNING

Never use a flame to check for gas leaks. Explosion causing injury or death may occur.

WARNING

If this unit is to be installed in a mobile or manufactured home application, the ductwork must be sized to achieve static pressures within the manufacturer's guidelines. All other installation guidelines must also be followed. Failure to do so may result in equipment damage, personal injury, and improper performance of the unit.

TABLE OF CONTENTS

SAFETY	2
INSTALLATION	2
START-UP	10
OPERATION	11
MAINTENANCE	13
CONTROL SYSTEM DIAGNOSTICS	14
WIRING DIAGRAMS	15

Manufactured By
Allied Air Enterprises Inc.
A Lennox International Inc. Company
 215 Metropolitan Drive
 West Columbia, SC 29170



CAUTION

The installation of the furnace, wiring, warm air ducts, venting, etc. must conform to the requirements of the National Fire Protection Association; the National Fuel Gas Code, ANSI Z223.1 (latest edition) and the National Electrical Code, ANSI/NFPA No. 70 (latest edition) in the United States; the Canadian Installation Codes CAN/CGA-B149.1 & .2 (latest edition) and the Canadian Electrical Code Part 1, CSA 22.1 (latest edition) in Canada; and any state or provincial laws, local ordinances, or local gas utility requirements. Local authorities having jurisdiction should be consulted before installation is made. Such applicable regulations or requirements take precedence over the general instructions in this manual.

SAFETY

The following is a list of safety rules and precautions that must be followed when installing this furnace.

1. Use only with the type of gas approved for this furnace. Refer to the furnace rating plate.
2. Install this furnace only in a location and position as specified in the Location section on page 3 of these instructions.
3. Adequate clearance must be provided around the vent hood as specified in the Clearances section on page 4 of these instructions.
4. Never test for gas leaks with an open flame. Use a commercially available soap solution made specifically for the detection of leaks to check all connections, as specified in Gas Supply and Piping beginning on page 6 of these instructions.
5. Always install furnace to operate within the furnace's intended temperature-rise range with a duct system which has an external static pressure within the allowable range, as specified in Temperature Rise on page 11 of these instructions. See furnace rating plate.
6. The furnace is not recommended for use for temporary heating of buildings or structures under construction unless certain installation and operating conditions are adhered to, as specified in the Location section on page 3 of these instructions.

**WARNING**

In the State of Massachusetts:

This product must be installed by a licensed Plumber or Gas Fitter. When flexible connectors are used, the maximum length shall not exceed 36". When lever-type gas shutoffs are used, they shall be T-handle type.

INSTALLATION

These instructions must be hung on or near the furnace in a conspicuous place.

These units are single package air conditioners with gas heat designed for outdoor installation on a rooftop or a slab.

The units are completely assembled. All piping, refrigerant charge, and electrical wiring are factory installed and tested. The units require only electric power, gas piping, condensate drain, and duct connections, plus assembly of the heating vent hood at the point of installation.

If components are to be added to a unit to meet local codes, they are to be installed at the dealer's and/or customer's expense.

The size of unit for the proposed installation should be based on heat loss/heat gain calculation made according to the methods of Air Conditioning Contractors of America (ACCA).

These installation instructions are intended as a general guide only, for use by an experienced, qualified contractor.

These units are listed by UL:

- For use as a forced air furnace with cooling unit.
- For outdoor installation only.
- For installation on combustible material.
- For use with natural gas or propane gas.
(Conversion kit required for propane gas application.)

These units are not suitable for use with conventional venting systems.

IMPORTANT: The 15 SEER models have been designed and manufactured to meet ENERGY STAR criteria for energy efficiency. However, proper refrigerant charge and proper air flow are critical to achieve rated capacity and efficiency. Installation of this product should follow the manufacturer's refrigerant charging and air flow instructions. ***Failure to confirm proper charge and airflow may reduce energy efficiency and shorten equipment life.***

Inspection

As soon as the unit is received, it should be inspected for possible damage during transit. If damage is evident, the extent of the damage should be noted on the carrier's freight bill. A separate request for inspection by the carrier's agent should be made in writing.

Location

Use the following guidelines to select a suitable location for the unit.

1. Unit is designed for outdoor installation only. Unit must be installed so all electrical components are protected from water.
2. Condenser coils must have an unlimited supply of air.
3. For ground level installation, use a level prefabricated pad or use a level concrete slab. Do not tie the slab to the building foundation.
4. Maintain level within a tolerance of 1/4" maximum across the entire length or width of the unit.
5. Do not locate the unit where the combustion air supply will be exposed to any of the following substances:
 - Permanent wave solutions
 - Chlorinated waxes and cleaners
 - Chlorine-based swimming pool chemicals
 - Water softening chemicals
 - Deicing salts or chemicals
 - Carbon tetrachloride
 - Halogen-type refrigerants
 - Cleaning solvents (such as perchloroethylene)
 - Printing inks, paint removers, varnishes, etc.
 - Cements and glues
 - Antistatic fabric softeners for clothes dryers
 - Masonry acid washing materials
 - Chlorinated laundry products
 - Hydrochloric acid

Use of unit as a construction heater during any phase of construction is not recommended. Very low return air temperatures, harmful vapors, and operation of the unit with clogged or misplaced filters will damage the unit. However, if the installation and operating conditions specified below are followed, use of this unit for heating of buildings or structures under construction is permissible:

- The vent hood must be installed per these installation instructions.
- A room thermostat must control the furnace. The use of fixed jumpers that will provide continuous heating is not allowed.
- The return air duct must be provided and sealed to the unit.
- Return air temperature must be maintained between 60°F (16°C) and 80°F (27°C).
- Air filters must be installed in the system and must be maintained during construction.

- Air filters must be replaced upon construction completion.
- The input rate and temperature rise must be set per the unit rating plate.
- 100% outdoor air must be provided for combustion air requirements during construction. Installation of this unit in its intended outdoor location will accomplish this.
- The heat exchanger, components, duct system, air filter(s), and evaporator coil must be thoroughly cleaned following final construction cleanup.
- Following the final cleaning, all furnace operating conditions (including ignition, input rate, temperature rise, and venting) must be verified according to these instructions.

Exercise care when moving the unit. Do not remove any packaging until the unit is near the place of installation. An accessory lift kit can be purchased to aid in rigging (see Figure 1). Spreaders whose length exceed the largest dimension across the unit **must be used across the top of the unit**. Recommended spreader length: 3 ton and smaller package units – 44", 3.5 ton and larger units – 54".

Units may also be moved or lifted with a forklift while still in the factory-supplied packaging. **The lengths of the forks of the forklift must be a minimum of 42"**.

CAUTION

Before lifting a unit, make sure that the weight is distributed equally on the cables so that it will lift evenly.

Using Accessory Lift Kit

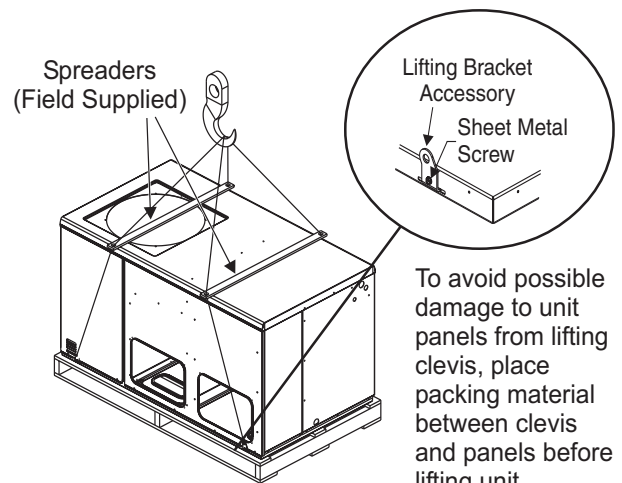

Figure 1

Roof Curb Installation

If a roof curb is used, follow the manufacturer’s Installation Instructions and be sure that all required clearances are observed (see following Clearances section).

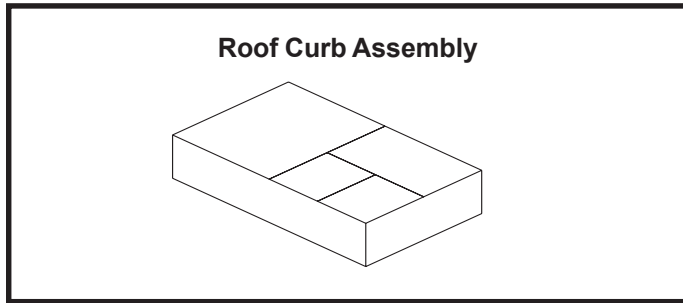

Figure 2

Clearances

All units require certain clearances for proper operation and service. Refer to Table 1 for the minimum clearances to combustibles as well as minimum clearances necessary for servicing and proper unit operation.

Minimum Clearance Requirements			
	To Combustible Material	For Service	For Proper Operation
Front	24"	48"	3"
Rear	0"	24"	3"
Condenser End	0"	24"	3"
Blower End	0"	30"	0"
Top	0"	36"	36"

Table 1

Figure 3 shows the minimum clearances to combustibles required above and below the vent hood. The minimum clearance in front of the vent hood is 24".

Do not permit overhanging structures or shrubs to obstruct condenser air discharge outlet or vent outlet.

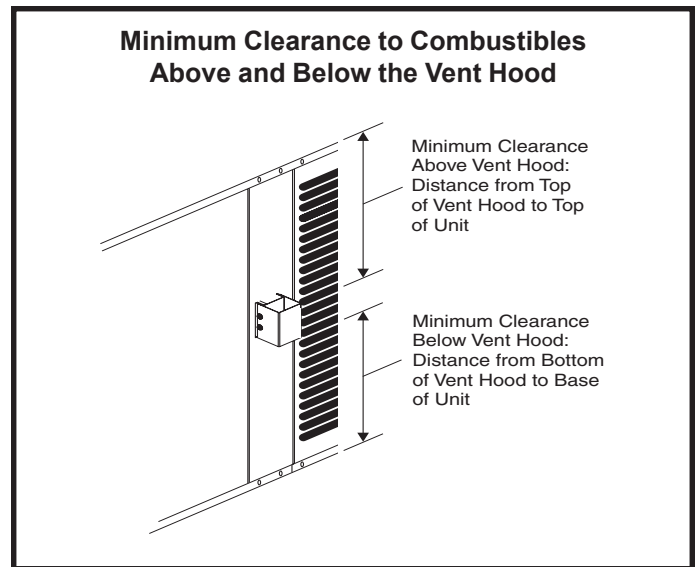

Figure 3

In the U.S., units may be installed on combustible floors made from wood or class A, B, or C roof covering material. In Canada, units may be installed on combustible floors.

Service Access

Access to all serviceable components is provided by four removable panels: filter compartment, blower compartment, furnace compartment, and top panel.

Combustion Products Discharge

The unit must be positioned such that combustion products discharged at the vent outlet will not result in building degradation and must be consistent with the National Fuel Gas Code, Z223.1 or CAN/CGA-B149.1 & .2.

The products of combustion are discharged through a screened opening in the front mullion. The horizontal vent system shall terminate at least 4' below, 4' horizontally from, or 1' above any door, window, or gravity air inlet into the building. The vent system shall terminate at least 3' above any forced air inlet located within 10'.

The unit shall be installed in a manner such that snow accumulation will not restrict the flow of flue products.

In addition to the above requirements, consideration must be given to prevent unwanted ice buildup from the vent condensate. The vent should not be located on the side of a building where the prevailing winter winds could trap the moisture, causing it to freeze on the walls or on overhangs (under eaves). The vent location should not discharge over

a sidewalk, patio, or other walkway where the condensate could cause the surface to become slippery.

The products of combustion must not be allowed to accumulate within a confined space and recirculate.

Vent Hood

The unit is shipped with the vent hood, screen, and sheet metal screws packed in the plastic bag containing the Installation Instructions.

To attach the vent hood and screen to the unit:

1. Insert the vent screen into the vent tube so that the screen is flush with the end of the tube, as shown in Figure 4.

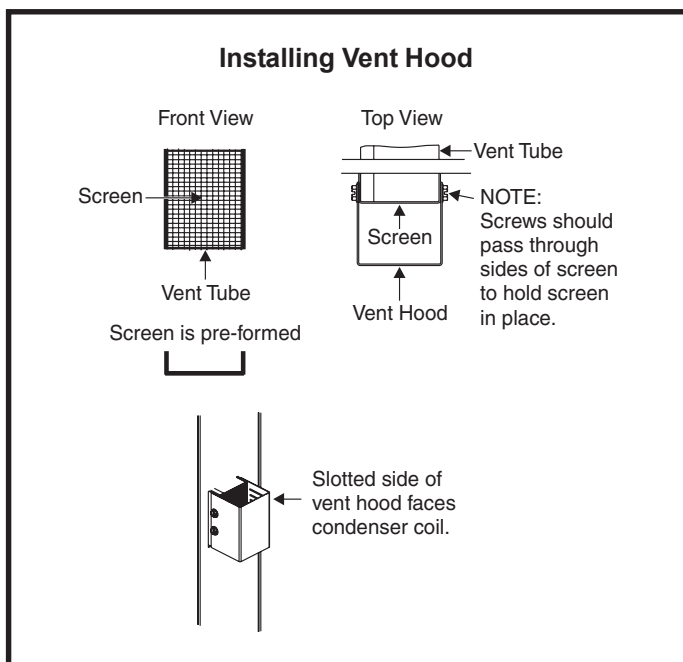

Figure 4

2. Position the vent hood over the vent tube so that the slotted side of the hood faces the condenser coil. Use the four sheet metal screws (provided) to secure the vent hood to the vent tube. The screws should pass through the sides of the screen in order to hold the screen in place.

Existing Venting Systems

When an existing furnace is removed or replaced, the original venting system may no longer be sized to properly vent the attached appliances. An improperly sized venting system can result in spillage of flue products into the living space, the formation of condensate, leakage, etc. See the accompanying **WARNING** box for proper test procedure.



CARBON MONOXIDE POISONING HAZARD

Failure to follow the steps outlined below for each appliance connected to the venting system being placed into operation could result in carbon monoxide poisoning or death.

The following steps shall be followed for each appliance connected to the venting system being placed into operation, while all other appliances connected to the common venting system are not in operation:

1. Seal any unused openings in the common venting system.
2. Visually inspect the venting system for proper size and horizontal pitch, as required in the National Fuel Gas Code, ANSI Z223.1/NFPA 54 (latest edition) or the CSA B149.1, Natural Gas and Propane Installation Codes and these instructions. Determine that there is no blockage or restriction, leakage, corrosion, or other deficiencies which could cause an unsafe condition.
3. As far as practical, close all building doors and windows between the space in which the appliance(s) connected to the venting system are located and other spaces in the building.
4. Close fireplace dampers.
5. Turn on clothes dryers and any appliance not connected to the venting system. Turn on any exhaust fans, such as range hoods and bathroom exhausts, so they are operating at maximum speed. Do not operate a summer exhaust fan.
6. Follow the lighting instructions. Place the unit being inspected in operation. Adjust the thermostat so appliance is operating continuously.
7. Test for spillage from draft hood equipped appliances at the draft hood relief opening after 5 minutes of main burner operation. Use the flame of a match or candle.
8. If improper venting is observed during any of the above tests, the venting system must be corrected in accordance with the National Fuel Gas Code, ANSI Z223.1/NFPA 54 (latest edition) and/or the CSA B149.1, Natural Gas and Propane Installation Codes.
9. After it has been determined that each appliance remaining connected to the venting system properly vents when tested as outlined above, return doors, windows, exhaust fans, fireplace dampers, and any other gas-fired burning appliance to their previous conditions of use.

Condensate Drain

The PGE/SG package unit is equipped with a 3/4" FPT coupling for condensate line connection. Plumbing must conform to local codes. Use a sealing compound on male pipe threads.

The condensate drain line must be properly trapped and routed to a suitable drain. See Figure 5 for proper drain arrangement. The drain line must pitch to an open drain or pump to prevent clogging of the line. Seal around the drain connection with suitable material to prevent air leakage into the return air system.

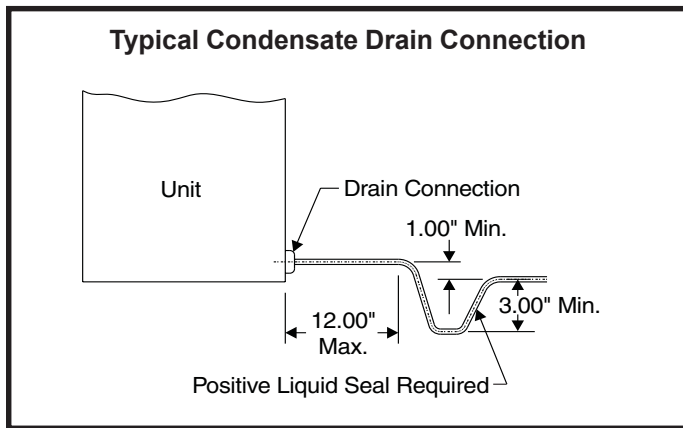

Figure 5

Ductwork

Ductwork should be designed and sized according to the methods in Manual Q of the Air Conditioning Contractors of America (ACCA).

A closed return duct system shall be used. This shall not preclude use of economizers or outdoor fresh air intake. It is recommended that supply and return duct connections at the unit be made with flexible joints.

The supply and return air duct systems should be designed for the CFM and static requirements of the job. **They should not be sized by matching the dimensions of the duct connections on the unit.**

Outdoor ductwork must be insulated and waterproofed.

Equipment is shipped for side ductwork connection. The unit can be converted to bottom ductwork connection by removing the duct covers located over the bottom duct openings and placing these covers over the side duct openings (see Figure 6).

To remove the bottom duct cover over supply opening:

1. Remove screw on cover nearest side opening.
2. Lift end of cover slightly and push to slide back screw/pin free from duct flange.

3. Slide duct cover out the side duct opening.

Filters

Air filters are to be used with this heating/cooling unit. Filters are not factory supplied in the unit. However, a filter frame accessory is available from the manufacturer that allows

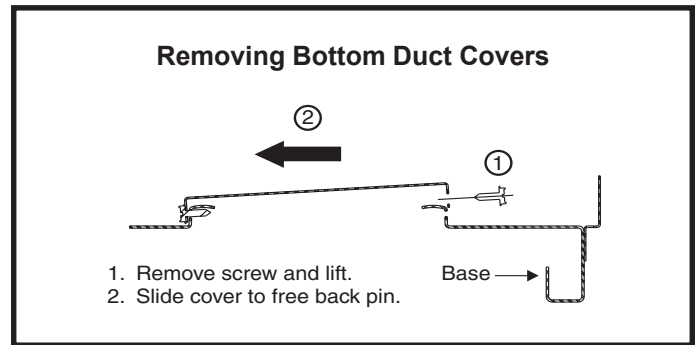

Figure 6

CAUTION

When fastening ductwork to side duct flanges on unit, insert screws through duct flanges only; do not insert screws through casing. If using bottom duct work, do not use screws to secure ductwork to bottom duct opening under drain pan side. Using screws to secure bottom duct may damage drain pan.

filters to be installed within the unit. If the filter frame accessory is not used, a filter must be installed in the duct work by the installer. Filters must always be installed ahead of the evaporator coil and must be kept clean or replaced. Dirty filters will reduce the airflow of the unit. Filters should be sized in accordance with Table 2.

Gas Supply and Piping

Refer to the furnace rating plate to make sure the furnace is equipped to burn the gas supplied (natural or propane). See **LPG/Propane Units, Tanks, and Piping** on page 7 for more information on converting to propane gas.

Gas supply piping should be installed in accordance with local codes and the regulations of the utility. In the absence of local codes, the latest edition of the National Fuel Gas Code ANSI Z223.1 (in the U.S.), or the Natural Gas and Propane Installation Codes CAN/CGA B149.1 & B149.2 (in Canada), should be followed. Piping must be of adequate size to prevent undue pressure drop. Consult the local utility or gas supplier for complete details on special requirements for sizing gas piping.

**Minimum Required Surface Area
for Disposable Filters**

Nominal Cooling	Filter Area (sq. ft.)
24,000	2.67
30,000	3.33
36,000	4.00
42,000	4.67
48,000	5.33
60,000	6.67

Table 2

The gas supply line should be routed through the grommet on the side of the unit. Refer to Figure 7 to locate this access opening.

If local codes allow the use of a flexible gas appliance connector, always use a new listed connector. Do not use a connector which has previously serviced another gas appliance.

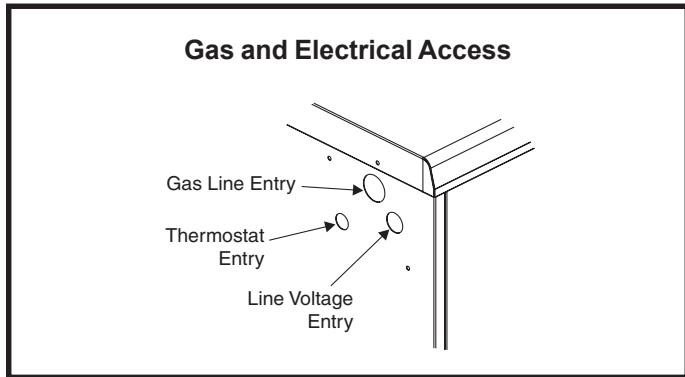

Figure 7

Pipe connections must be tight, and a non-hardening pipe compound resistant to liquefied petroleum gases should be used.

Install a manual shutoff valve in the gas connection to the unit, external to the casing, in accordance with local codes. An 1/8" NPT plugged tapping, accessible for test gauge connection, must be installed immediately upstream of the gas supply connection to the unit. A sediment trap (drip leg) shall be installed as close as practical to the gas supply inlet of the unit.

The furnace must be isolated from the gas supply piping system by closing the individual manual shutoff valve during any pressure testing of the gas supply piping system at test pressure equal to or less than 1/2 psig (3.5 kPa) or 14" W.C. If the piping system is to be tested at pressures in excess of 1/2 psig (3.5 kPa), the furnace and its appliance main gas valve must be disconnected from the gas supply piping system.

After gas piping is complete, carefully check all piping connections (factory and field) for gas leaks. Use a leak detecting solution or other preferred means. Some soaps used for leak detection are corrosive to certain metals. Carefully rinse piping thoroughly after leak detection has been completed.

⚠ WARNING

The gas valve supplied with this furnace is rated at 1/2 psig maximum. Any higher pressure may rupture the pressure regulator diaphragm and may cause overfiring of the burners and improper burner operation. The overfiring may result in the creation of carbon monoxide which could cause asphyxiation.

LPG/Propane Units, Tanks, and Piping

Units are shipped equipped for natural gas, but can be converted to LPG/propane in the field by an approved licensed technician.

⚠ WARNING

FIRE OR EXPLOSION HAZARD

Failure to follow the safety warnings exactly could result in serious injury, death, or property damage.

Never test for gas leaks with an open flame. Use a commercially available soap solution made specifically for the detection of leaks to check all connections. A fire or explosion may result causing property damage, personal injury, or loss of life.

All LPG/propane gas equipment must conform to the safety standards of the National Fire Protection Association.

For satisfactory operation, LPG/propane gas pressure must be a minimum of 11" W.C. at the unit under full load.

Complete information regarding tank sizing for vaporization, recommended regulator settings, and pipe sizing is available from most regulator manufacturers and LPG/propane gas suppliers.

 **WARNING**

Any conversion of a natural gas unit to propane gas must be done by qualified personnel using a conversion kit available from the manufacturer, following the instructions in the conversion kit. If done improperly, overfiring of the burners and improper burner operation can result. This can create carbon monoxide which could cause asphyxiation.

Check all connections for leaks when piping is completed, using a soapy solution. **Some soaps used for leak detection are corrosive to certain metals. Carefully rinse piping thoroughly after completing leak detection.**

Electrical Wiring

All wiring should be done in accordance with the National Electrical Code, ANSI/NFPA No. 70 (latest edition); Canadian Electrical Code Part 1, CSA C22.1 (latest edition); or local codes where they prevail. Use wiring with a temperature limitation of 75°C minimum. Run the electric power supply through a fused disconnect switch to the connection box of the unit and connect as shown in the wiring diagram located on the inside of the control access panel.

Power supply to the unit must comply with all applicable codes and the National Electrical Code (NEC) or Canadian Electrical Code (CEC). A fused disconnect switch should be field provided for the unit. The switch must be separate from all other circuits.

If any of the wire supplied with the unit must be replaced, replacement wire must be of the type shown on the wiring diagram. Electrical wiring must be sized to carry minimum circuit ampacity marked on the unit. **Use copper conductors only.** Each unit must be wired with a separate branch circuit and be properly fused.

Thermostat

The room thermostat should be located on an inside wall where it will not be subject to drafts, sun exposure, or heat from electrical fixtures or appliances. Follow the manufacturer's instructions enclosed with thermostat for general installation procedure. Color-coded insulated wires (#18 AWG) should be used to connect thermostat to unit.

 **CAUTION**

When connecting electrical power and control wiring to the unit, waterproof type connectors must be used so that water or moisture cannot be drawn into the unit during normal operation.

Four wires are required for cooling. The heat anticipator setting is 0.7 amp.

Compressor

Units are shipped with compressor mountings factory-adjusted and ready for operation. **Caution: Do not loosen compressor mounting bolts.**

Typical Wiring Connections

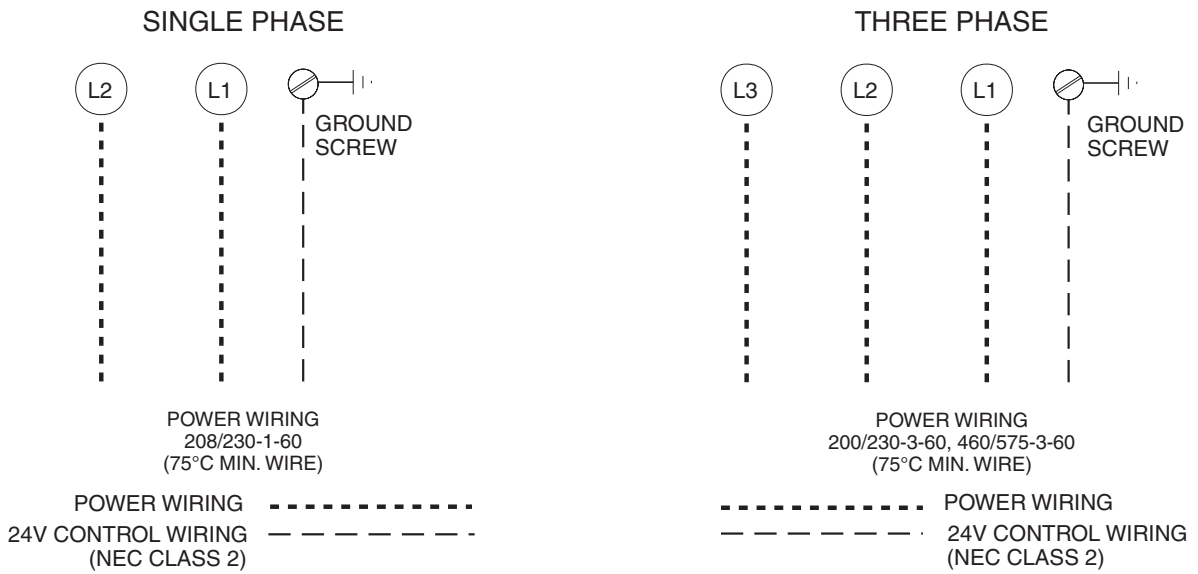
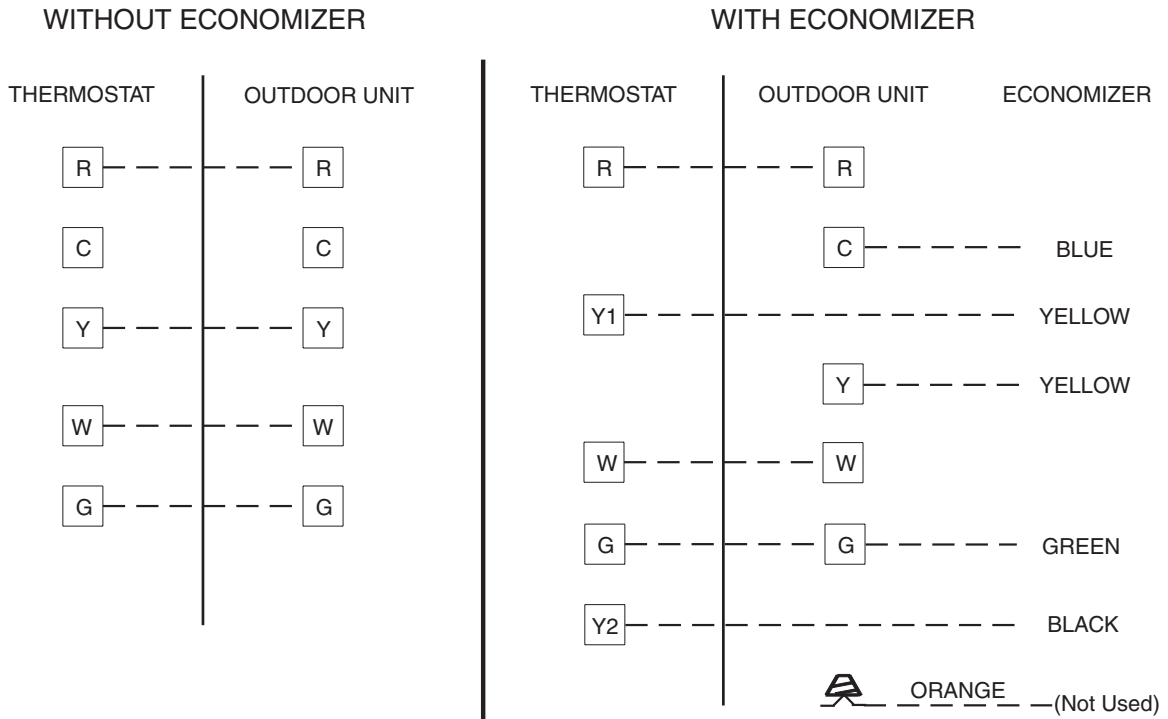

⚠ CAUTION

Do not connect **C** connections except when required by the indoor thermostat. Refer to the thermostat installation instructions.

Figure 8

START-UP

For Your Safety Read Before Lighting



Furnace is equipped with a direct ignition control. Do not attempt to manually light the burners.

Pre-Start Check List

Complete the following checks before starting the unit:

1. Check the type of gas being supplied. Be sure it is the same as listed on the unit nameplate.
2. Make sure that the vent hood has been properly installed.

To Light Burners:

1. Turn off electrical power to unit.
2. Turn the thermostat to lowest setting.
3. Turn the gas control knob, or slide the gas control switch, to the "ON" position (see Figure 9).
4. Turn on electrical power to the unit.
5. Set the room thermostat to the desired temperature. (If the thermostat "set" temperature is above room temperature, the burners will light after the pre-purge time expires.)

To Shut Down Burners:

1. Turn off electrical power to unit.
2. Turn the gas control knob, or slide the gas control switch, to the "OFF" position (see Figure 9).

Post-Start Check List

After the entire control circuit has been energized and the heating section is operating, make the following checks:

1. Check for gas leaks, using soapy solution, in the unit piping as well as the supply piping.
2. Check for correct manifold gas pressures (see following Checking and Adjusting Gas Input section).
3. Check the supply gas pressure. It must be within the limits shown on the rating plate. Supply pressure should be checked with all gas appliances in the building at full fire. At no time should the supply pressure during standby exceed 13" w.c., nor should it be less than 5" w.c. for

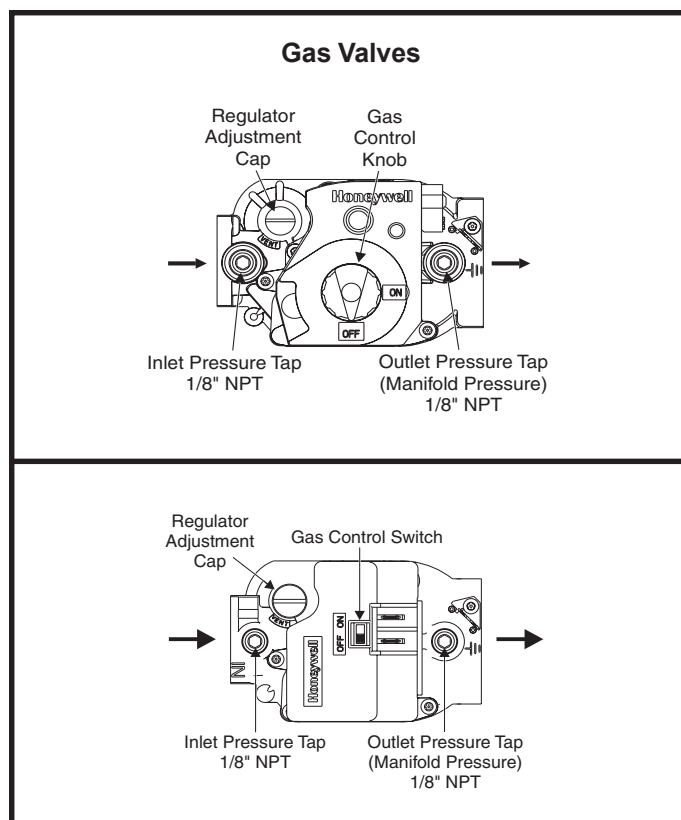

Figure 9

natural gas or 11" W.C. for propane gas with the burners in operation. If gas pressure is outside these limits, contact the gas supplier for corrective action.

4. Adjust temperature rise to be within the range specified on the rating plate.

Checking and Adjusting Gas Input

For purpose of input adjustment, the minimum permissible gas supply pressure is 5" w.c. for natural gas and 11" w.c. for propane.

Gas input must never exceed the input capacity shown on the rating plate. **The furnace is equipped for natural gas rated inputs with manifold pressure of 3.5" w.c.**

The manifold pressure can be measured by shutting off the gas, removing the pipe plug in the downstream side of the gas valve, and connecting a water manometer or gauge. To adjust the regulator, turn the adjusting screw on the regulator clockwise to increase pressure and input or counterclockwise to decrease pressure and input. **The final manifold pressure should not vary more than 0.3" w.c. from the above specified pressure.** See Figure 9 to assist in locating the regulator on the gas valve.

For Natural Gas: Check the gas input rate by observing the gas meter, when available, making sure all other gas appliances are turned off. The test hand on the meter should be timed for at least one revolution. Note the number of seconds for one revolution.

$$\text{BTU/HR INPUT} = \frac{\text{Cubic Feet Per Revolution}}{\text{\# Seconds Per Revolution}} \times 3600 \times \text{Heating Value}$$

The heating value of the gas can be obtained from the local utility company.

For Propane Gas: The only check for the gas input rate is to properly adjust the manifold pressure using a manometer. Typical manifold set point for installations at altitudes from 0 to 4500 feet above sea level is 10.0" W.C.

Temperature Rise

Check the temperature rise and, if necessary, adjust blower speed to maintain temperature rise within the range shown on the unit rating plate.

High Altitude

Ratings are shown on the rating plate for elevations up to 4500 feet. For elevations above 4500 feet, ratings should be reduced at a rate of 4% for each 1000 feet above sea level. See the National Fuel Gas Code Z223.1 (latest edition) or the Canadian Installation Codes CAN/CGA-B149.1 & B149.2 for further details.

Secure Owner's Approval

When the system is functioning properly, secure the owner's approval. Show the owner the location of all disconnect switches and the thermostat. Instruct the owner on how to start and stop the unit and how to adjust temperature settings within the limitations of the system.

OPERATION

Cooling System

The cooling system is a complete factory package utilizing an air-cooled condenser. The compressor is hermetically sealed and base mounted with rubber-insulated hold-down bolts.

Unit compressors have internal protection. In the event there is an abnormal rise in the temperature of the compressor, the protector will open and cause the compressor to stop.

Cooling Sequence of Operation

When the thermostat calls for cooling, R is closed to G and Y (see the wiring diagrams beginning on page 15). This action completes the low voltage control circuit, energizing the compressor, condenser fan motor, and blower motor.

Blower Delay – Cooling

The circulating air blower is controlled by a timing circuit in the integrated blower/ignition control. Timings are not adjustable. Blower "on" delay is 5 seconds after the compressor starts and blower "off" timing is 90 seconds after the cooling system shuts down.

System Performance

This equipment is a self contained, factory optimized refrigerant system, and should require no adjustments when properly installed. If however unit performance is questioned, perform the following checks.

Suction Superheat			
Series	Size	Suction Superheat +/-3 Deg°F @ ARI Conditions 82° OD, 80° IDDB/67° IDWB	Liquid Line Subcooling +/-2 Deg°F @ ARI Conditions 82° OD, 80° IDDB/67° IDWB
4PGE13	24	17	-
	30	15	-
	36	19	-
	42	13	-
	48	15	-
	60	18	-
4PGE15	24,30	-	12
	36	-	15
	42	-	10
	48	-	7
	60	-	8

Table 3

Insure unit is installed per manufacturer’s instructions and that line voltage and air flows are correct. Refer to Table 3 for proper superheat or subcooling values. Check superheat settings by measuring pressure at the suction line service port. For TXV systems, measure pressure at the liquid service port. Take line temperature within 2 inches of service port connection to its main tube. If unit superheat/subcooling varies by more than table allowance, check internal seals, service panels and duct work for air leaks, as well as restrictions and blower speed settings. If unit performance remains questionable, remove charge, evacuate to 500 Microns, and weigh in refrigerant to name plate charge. It is critical that the exact charge is re-installed. Failure to comply will compromise system performance. If unit performance is still questionable, check for refrigerant related problems such as, blocked coil or circuits, malfunctioning metering devices or other system components.

Heating System

With the proper thermostat and sub-base, continuous blower operation is possible by closing the R to G circuit. Cooling blower delay is also functional in this mode.

Heating Sequence of Operation

1. When the thermostat calls for heat, the combustion blower is energized by the ignition control.
2. When the speed of the combustion blower reaches proper RPM, the pressure switch closes, initiating the pre-purge timing (30 seconds nominal).
3. When pre-purge has expired, the ignition control energizes the gas valve, the spark electrode, and the flame sensor. The igniter sparks for 10 seconds, and the flame sensor senses that flame has been established. If the flame sensor does not sense that flame has been established

in the 10-second interval, then the ignition control will de-energize the gas valve.

4. The ignition control is designed to repeat this “trial for ignition” a total of three times. If, at the end of the third trial, a flame still has not been established, the ignition control will repeat the trial for ignition sequence 1 hour later. The 1-hour retry is indefinite. The ignition control can be reset by interrupting the unit power or the thermostat circuit.
5. Thirty seconds (nominal) after the initial trial for ignition, the circulation air blower will start.
6. When the thermostat is satisfied, the combustion blower and gas valve are de-energized. The circulating air blower motor will continue to run for a short period after the thermostat is satisfied.

Circulating Air Blower

Depending on the package unit model, the blower motor will be either a multi-tap PSC motor or a variable speed motor.

PSC Motor

The circulating air blower is controlled by a timing circuit in the integrated blower/ignition control. Timings are not adjustable.

Cooling – Blower “on” delay is 5 seconds after call for cooling. Blower “off” delay is 90 seconds after the cooling system shuts down.

Heating – Blower “on” delay is 30 seconds nominal after burner ignition. Blower "off" delay is approximately 120 seconds after the thermostat is satisfied.

Adjusting Airflow (Variable Speed Motor Equipped Units Only)

Model		Motor HP	ADJUST Setting	HEAT Setting	Cooling CFM @.50 Static			
Nominal Cooling kBTU	Heating Input kBTU				COOL Setting A	COOL Setting B	COOL Setting C	COOL Setting D
24, 30	68	1/3	NORM	A	1000	800	600	900
36	68	1/2	NORM	B	1200	1000	800	1100
36	90	1/2	NORM	A	1200	1000	800	1100
42, 48, 60	83	3/4	NORM	C	1800	1600	1400	1200
42, 48, 60	110	3/4	NORM	C	1800	1600	1400	1200
42, 48, 60	138	3/4	NORM	A	1800	1600	1400	1200

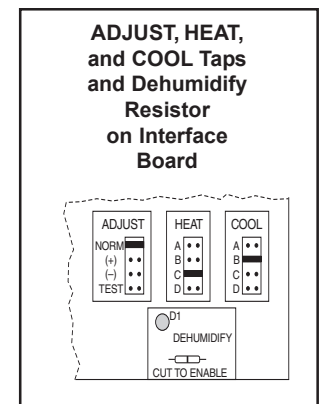

Table 4

MAINTENANCE

Variable Speed Motor

Units equipped with a variable speed circulation air blower motor will deliver a constant airflow within a wide range of external static pressures. Other features of this variable speed motor include:

Soft Start/Stop – The variable speed motor will slowly ramp up to normal operating speed. This minimizes noise and increases comfort by eliminating the initial blasts of air encountered with standard motors. At the end of a cooling or heating cycle, the motor will slowly ramp down.

Circulation Airflow Adjustments – The controls include a variable speed motor interface board. The ADJUST tap can be used to raise (+) or lower (–) the airflow by 15%.

Heating and Cooling Airflows – The units are factory set for the correct heating and cooling airflows. However, airflow changes can be made by moving the position of the HEAT and COOL taps (see Table 4).

Continuous Blower – The comfort level of the living space can be enhanced when using this feature by allowing continuous circulation of air between calls for cooling or heating. The continuous circulation of air occurs at half the full cooling airflow rate. To use this feature, place the thermostat fan switch into the ON position.

Cooling Airflow Ramp Up – At the beginning of a call for cooling, the blower will run at 80% of full airflow for 7.5 minutes. This improves the system's moisture removal and saves blower power during cooling start.

Reduced Airflow Operation (Dehumidification) – For situations where humidity control is an issue, the variable speed motor can be connected to operate at a 25% reduction in the normal airflow rate. The variable speed motor interface board provides for connection of a humidistat on the HUM terminal. When a humidistat is connected, the dehumidifier resistor on the interface must be cut. The humidistat should be wired to open during high humidity, which will reduce blower airflow.

Safety Controls

The control circuit includes the following safety controls:

Limit Control

This control is located inside the heating compartment and is designed to open at abnormally high air temperatures. It resets automatically. The limit control operates when a high temperature condition, caused by inadequate airflow, occurs. This causes the ignition control to close the gas valve. The circulation air blower continues to operate in this situation.

Pressure Switch

The pressure switch prevents the gas valve and igniter from being energized if there is insufficient combustion air due to a failed combustion blower or a blocked vent.

WARNING

ELECTRICAL SHOCK, FIRE, OR EXPLOSION HAZARD

Failure to follow the safety warnings exactly could result in dangerous operation, serious injury, death, or property damage.

Improper servicing could result in dangerous operation, serious injury, death, or property damage.

- Before servicing, disconnect all electrical power to furnace.
- When servicing controls, label all wires prior to disconnecting. Reconnect wires correctly.
- Verify proper operation after servicing.

Flame Sensor

If the ignition control does not receive a signal from the flame sensor indicating that the burners have established flame, the gas valve closes after the 10-second trial for ignition period.

Rollout Switch

The switch is located above the main burners. In the event of a sustained flame rollout, the rollout switch causes the ignition control to close the gas valve. To reset, push the button on top of the switch.

Auxiliary Limit (42, 48, and 60 units only)

This control is located in the side of the circulation air blower housing. The switch causes the ignition control to close the gas valve should the circulation blower fail to operate. This control resets automatically.

It is recommended that this furnace be inspected by a qualified service technician at the beginning of each heating season.

Filters

Filters should be checked at least every 6 weeks. Disposable filters should be replaced when dirty, and cleanable filters should be cleaned regularly. It is important to keep the air filters clean, as dirty filters can restrict airflow and the blower and induced draft motors depend upon sufficient air flowing across and through them to keep from overheating.

Lubrication

The blower motor and induced draft motor are pre-lubricated by the manufacturer and do not require further lubricating attention. However, the motors should be cleaned periodically to prevent the possibility of overheating due to an accumulation of dust and dirt on the windings or on the motor exterior.

Burners

Light the burners and allow to operate for a few minutes to establish normal burning conditions. Observe the burner flames. Compare this observation to Figure 10 on page 14 to determine if proper flame adjustment is present. Flame should be predominantly blue in color and strong in appearance. Check that all burners are lit, and that the flame does not impinge on the sides of the heat exchanger.

Distorted flame or yellow tipping of the natural gas burner flame, or long yellow tips on propane, may be caused by lint accumulation or dirt inside the burner or burner ports, at the air inlet between the burner and manifold pipe, or obstructions over the burner orifice.

Use a soft brush or vacuum to clean the affected areas.

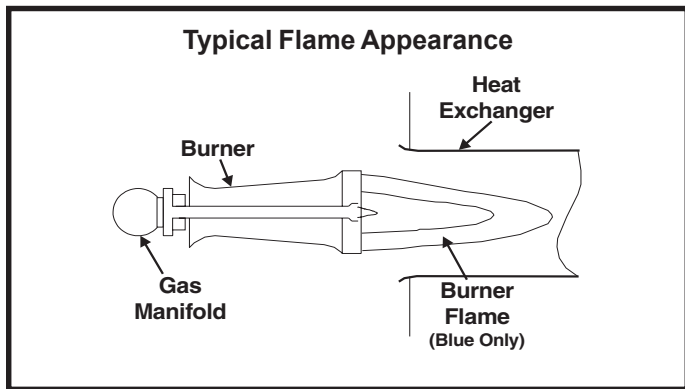

Figure 10

Outdoor Coil

Dirt and debris should not be allowed to accumulate on the outdoor coil surface or other parts in the air circuit. Cleaning should be as often as necessary to keep coil clean. Use a brush, vacuum cleaner attachment, or other suitable means. If water is used to clean the coil, be sure the power to unit is shut off prior to cleaning. **Care should be used when cleaning the coil so that the coil fins are not damaged.**

Do not permit the hot condenser air discharge to be obstructed by overhanging structures or shrubs.

Vent Outlet

Visually inspect vent outlet periodically to make sure there is no buildup of soot and dirt. If necessary, clean to maintain adequate opening to discharge flue products.

Fault Codes

LED Status	Flashing Rate	Fault Description
Slow Flash	One flash per second	Normal operation: No call for heat
Fast Flash	Two flashes per second	Normal operation: Call for heat
2 Flash	Two flashes in second with 1-second pause	System lockout: Failed to detect or sustain flame
3 Flash	Three flashes in 1.5 seconds with 1-second pause	Pressure switch open or closed
4 Flash	Four flashes in 2 seconds with 1-second pause	High limit or rollout switch open
5 Flash	Five flashes in 2.5 seconds with 1-second pause	Flame sensed and gas valve not energized
Steady	--	Internal failure: Micro-controller failure; self-check

Table 5

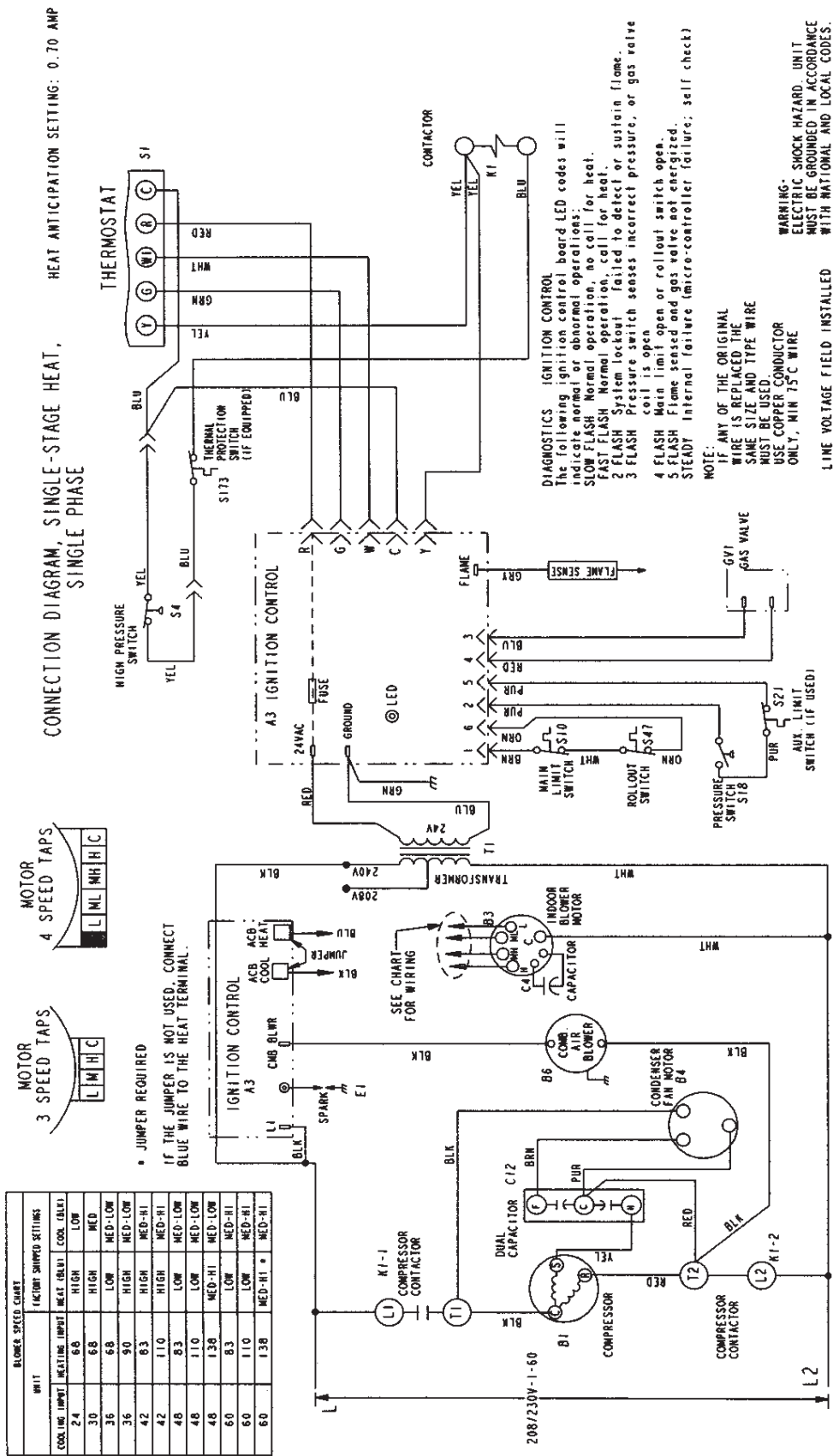

Figure 11

Connection Diagram
 Single Phase – PSC Motor

537317-01

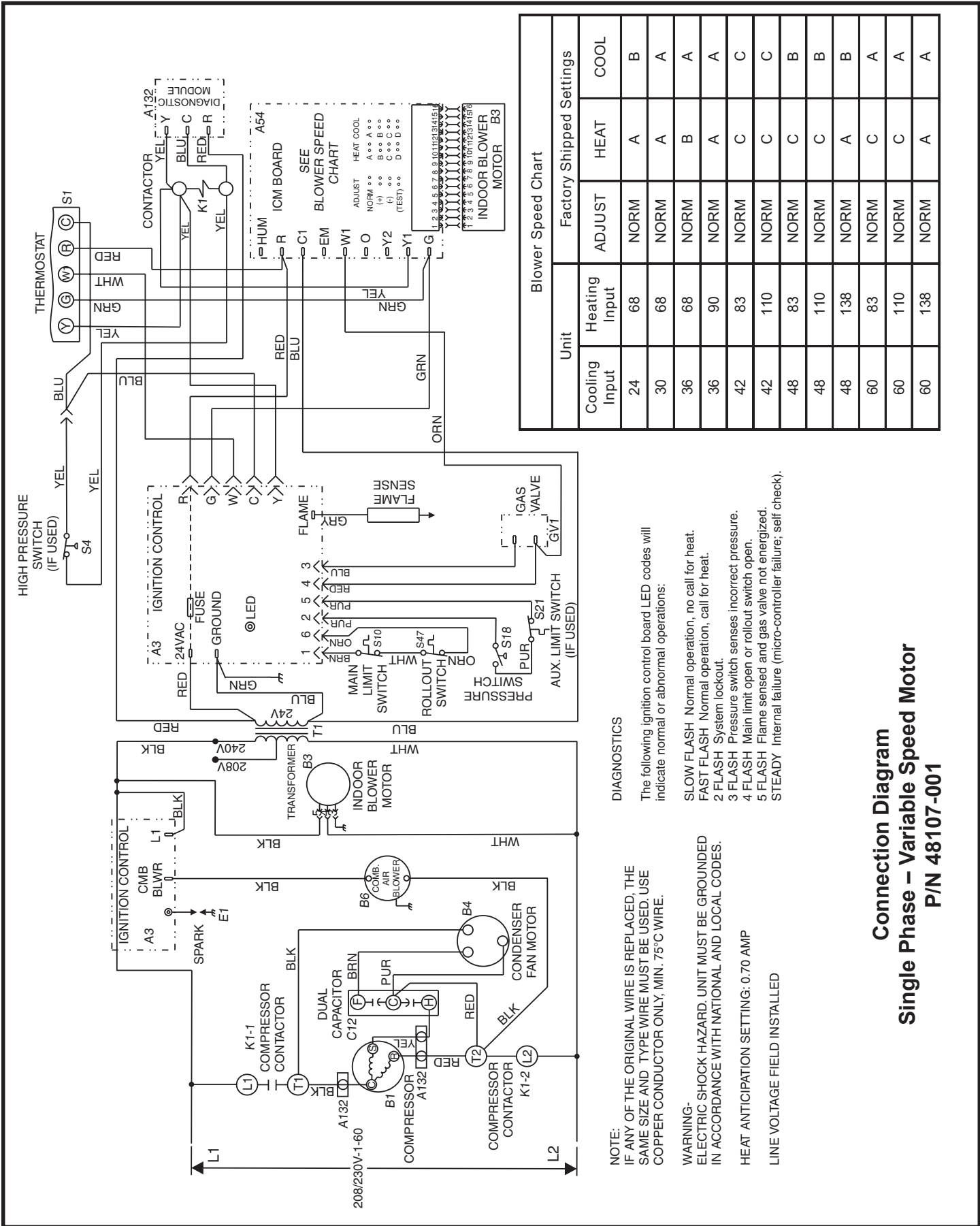

Figure 12

NOTE:
IF ANY OF THE ORIGINAL WIRE IS REPLACED, THE SAME SIZE AND TYPE WIRE MUST BE USED. USE COPPER CONDUCTOR ONLY, MIN. 75°C WIRE.

WARNING-
ELECTRIC SHOCK HAZARD. UNIT MUST BE GROUNDED IN ACCORDANCE WITH NATIONAL AND LOCAL CODES.

HEAT ANTICIPATION SETTING: 0.70 AMP

LINE VOLTAGE FIELD INSTALLED

DIAGNOSTICS

The following ignition control board LED codes will indicate normal or abnormal operations:

- SLOW FLASH Normal operation, no call for heat.
- FAST FLASH Normal operation, call for heat.
- 2 FLASH System lockout.
- 3 FLASH Pressure switch senses incorrect pressure.
- 4 FLASH Main limit open or rollout switch open.
- 5 FLASH Flame sensed and gas valve not energized.
- STEADY Internal failure (micro-controller failure; self check).

Connection Diagram
Single Phase – Variable Speed Motor
P/N 48107-001